

ANALYSIS OF DETERMINING CRITICAL COMPONENTS USING FMECA METHOD IN SEAWATER PUMP OF DIESEL GENERATOR CATERPILLAR 3412

Syaiful Hasan, Erpan Sahiri, Suprayitno, Endin Tri Hartanto

Indonesia Naval Technology College,
Bumimoro-Morokrembangan Surabaya 60187, Indonesia

ABSTRACT

The seawater pump on the Caterpillar 3412 Diesel Generator is one of the important component to make the Diesel generator can work well. This section serves to circulate seawater for the heat transfer process. The seawater pump is part of a cooling system of the engine which keeps the engine temperature from being too overheat. Seawater pumps with continuous operational conditions, resulting in reduced component reliability. This study applies the FMECA method to identify opportunities for failure at the seawater pump. From the calculation of FMECA, it is obtained an assessment of the level of risk from a failure model that can give priority scale to preventive maintenance that can be done in the future. FMECA analysis of 27 components in seawater pump on the Diesel Generator, found 7 components that had RPN values above the average. The following are the 4 components with the highest RPN value, namely Shaft (7C-3493) RPN value 420,44; Key (175-6716) RPN value 300,31; Bearing Inner (4M-6107) RPN value 285 and Bearing Roller (3N-8463) RPN value 253,13. Components that have high RPN values require more attention, such as routine checks and periodic maintenance.

Keyword: Seawater pump, Caterpillar 3412 Diesel Generator, FMECA, RPN.

1. INTRODUCTION.

The engine temperature greatly affects the performance of the engine. If the engine temperature is too cold, the brake power released will be smaller because it has to increase the engine temperature at a working temperature first. Conversely, if the engine temperature is too hot it will reduce the performance and brake power (Choudhary, Tiwari, Vardhan, & Kaushal, 2014). To maintain the temperature of the diesel engine not overheat needed a cooling system. In the cooling system have a part in the circulating seawater is a seawater pump. The seawater is circulated to the heat exchanger to cooling the freshwater. The freshwater is tasked with cooling all components of the engine.

Continuous operation of the diesel generator will reduce the value of reliability components, so we need to make a preventive maintenance schedule. Especially the seawater pump which has the most frequent amount of damage compared to other system units. It is necessary to identify what components can cause failure and what are the consequences of the failure. This must be done to maintain the readiness of the diesel generator.

Previous literature used as references include Jun & Huibin (2012) researching about Reliability Analysis of Aircraft Equipment Based on FMECA Method. Hasbullah & Ahmad (2015) researching about Failure Analysis of Tyre Production Process Using FMECA Method. Deng (2015) researching about A Research on Subway Physical Vulnerability Based on Network Theory and FMECA. Renjith, kalathil, Kumar, & Madhavan

(2018) researching about Fuzzy FMECA (failure mode effect and criticality analysis) of LNG Storage Facility.

This research uses the FMECA method to identify the causes of failures and their effects on the system, then the risks are assessed using Severity, Occurrence and Detection assessments so that the most critical parts are identified. The part that has the highest Risk Priority Number (RPN) value is categorized as the riskiest component. Those components must be given priority for repairs.

2. MATERIAL AND METHODS.

2.1. Seawater Pump.

The type of seawater pump under study is a seawater pump driven by engine speed. The pump type is a centrifugal pump. Centrifugal pump as a particular case of turbomachinery. A typical centrifugal pump (Figure 1) consists of an impeller, which has some channels delimited by curved blades, that rotates inside a spiral shape casing (the volute). Rotation of the impeller forces the fluid (usually liquid) to circulate through the pump from the axial to the radial direction while energy is transferred to the fluid (Karassik, Messina, Cooper, & Heald, 2001). During this continuous process non-steady fluid-dynamic forces are produced, both at single frequencies and with broad-band spectra. The former is usually associated with the frequency of rotation, the passing-blade frequency, and their harmonics. Excitation at the frequency of rotation may be provoked by impeller whirling, when the impeller has an orbital motion coupled to the

rotation, and, also, by small manufacturing imperfections in the impeller. Excitation at the passing-blade frequency (frequency of rotation multiplied by the number of blades of the impeller) is a consequence of the finite thickness of the blades, which causes flow disturbances in the

volute associated with the passage of each blade. The effects of those excitation mechanisms may be substantially modified by impeller-stator interaction phenomena, which are dependent on the point of operation of the pump (Parrondo, Fernandez, Santolaria, & Gonzalez, 1996).

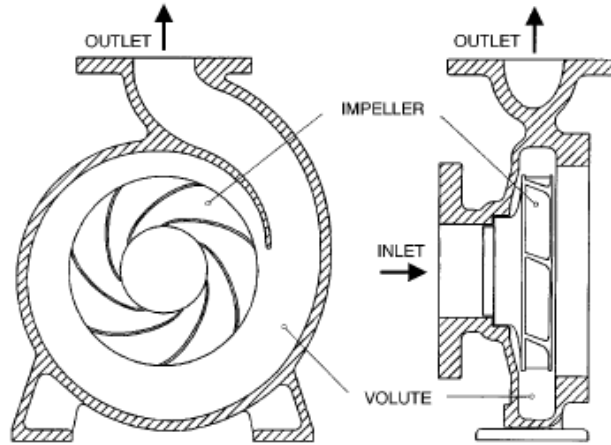

Fig. 1 Centrifugal Pump.
(Parrondo, Velarde, & Santolaria, 1998)

2.2. FMECA

The FMECA was originally developed by the National Aeronautics and Space Administration (NASA) to improve and verify the reliability of space program hardware. MIL-STD-785, entitled Reliability Program for System and Equipment Development and Production. Failure Mode, Effects and Criticality Analysis call out the procedures for performing a FMECA on equipment or systems. MIL-STD-1629 is the military standard that establishes requirements and procedures for performing a FMECA, to evaluate and document, by failure mode analysis, the potential impact of each functional or hardware failure on mission success, personnel and system safety, maintainability and system performance. Each potential failure is ranked by the severity of its effect so that corrective actions may be taken to eliminate or control design risk. High risk items are those items whose failure would jeopardize the mission or endanger personnel. The techniques presented in this standard may be applied to any electronic or

mechanical equipment or system. MIL-STD-1629 is applicable during the development phases of all DoD systems and equipment as well as commercial and industrial products (Borgovini, Pemberton, & Rossi, 1993).

Risk Priority Number (RPN) is the result of multiplication weights of Severity (S), Occurrence (O) and Detection (D). These results will be able to determine the critical components of the system.

$$RPN = (S) \times (O) \times (D) \tag{1}$$

The Risk Priority Number is used to rank and identify the concerns or risks associated with the operation due to the design. This number will provide a means to prioritize which components should be evaluated by the team to reduce their calculated risk through some type of corrective action or maintenance efforts. However, when severity is at a high level, immediate corrective action may be given regardless of the resultant RPN (ARMY, 2006).

Table 1. FMECA's Severity, Occurrence, and Detection.

Severity	Occurrence	Detection	Score
Dangerously High	$\lambda > 0.01$	Absolute Uncertainty	10
Extremely High	$0.01 > \lambda > 5 * 10^{-3}$	Very Remote	9
Very High	$5 * 10^{-3} > \lambda > 2.5 * 10^{-3}$	Remote	8
High	$2.5 * 10^{-3} > \lambda > 10^{-3}$	Very Low	7
Moderate	$10^{-3} > \lambda > 5 * 10^{-4}$	Low	6
Low	$5 * 10^{-4} > \lambda > 10^{-4}$	Moderate	5
Very Low	$10^{-4} > \lambda > 5 * 10^{-5}$	Moderately High	4
Minor	$5 * 10^{-5} > \lambda > 10^{-6}$	High	3
Very Minor	$10^{-6} > \lambda > 10^{-7}$	Very High	2
None	$10^{-7} > \lambda$	Almost Certain	1

(Melani et al., 2018)

Table 2. Consequence/severity Level.

Severity Level	Descriptions for Severity Level	Definition for Severity Level	Applicable to Functional Groups for
1	Minor, Negligible,	Function is not affected, no significant operational delays. Nuisance.	Propulsion Directional Control Drilling Position Mooring (Station Keeping) Hydrocarbon Production and Processing Import and Export Functions
2	Major, Marginal, Moderate	Function is not affected, however failure detection/corrective measures not functional. OR Function is reduced resulting in operational delays.	
3	Critical, Hazardous, Significant	Function is reduced, or damaged machinery, significant operational delays	
4	Catastrophic, Critical	Complete loss of function	

(American Bureau of Shipping, 2016)

Table 3. Probability of Failure.

Likelihood Descriptor ⁽¹⁾	Description
Improbable	Fewer than 0.001 events/year
Remote	0.001 to 0.01 events/year
Occasional	0.01 to 0.1 events/year
Probable	0.1 to 1 events/year
Frequent	1 or more events/year

(American Bureau of Shipping, 2016)

Table 4. Risk Matrix.

Severity Level	Likelihood of Failure				
	Improbable	Remote	Occasional	Probable	Frequent
4	Medium	High	High	High	High
3	Low	Medium	High	High	High
2	Low	Low	Medium	High	High
1	Low	Low	Low	Medium	Medium

(American Bureau of Shipping, 2016)

2.3. Research Methodology

To solve problems in the observed research, steps are needed and determined to describe the approach and model of the problem. The steps taken are:

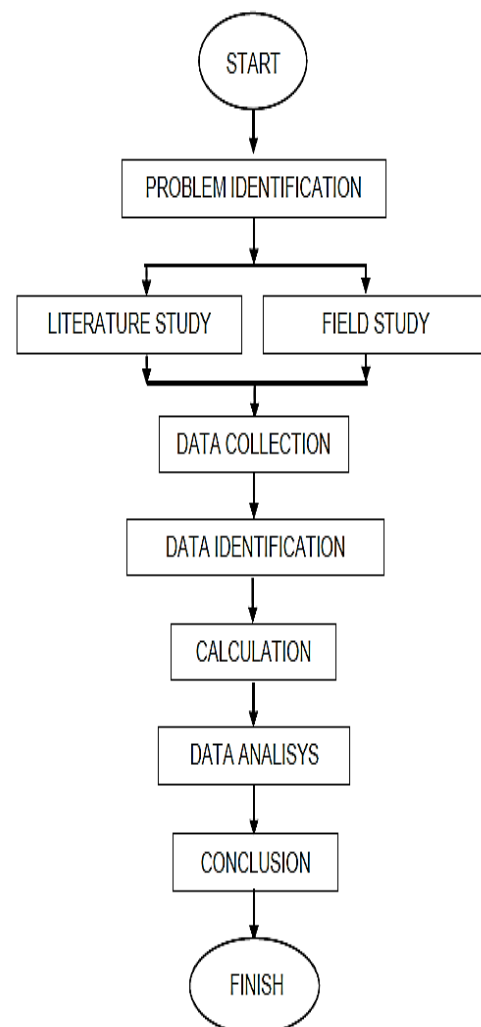

Fig. 2 Research Methodology.

3. RESULT AND DISCUSSION.

This is the arrangement components of seawater Pump on the Caterpillar 3412 Diesel Generator

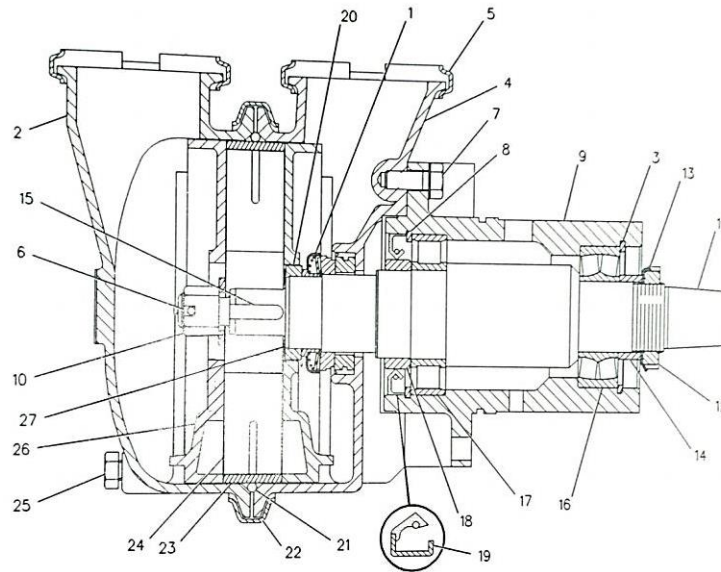

Fig. 3 Sea Water Pump.
(Caterpillar, 2004)

Data identification of potential component failures that affect the operation of Sea Water Pump is obtained below:

Table 5. Identification of Potential Failure.

NO	ITEM	PART NUMBER	POTENTIAL FAILURE	DAMAGE	CODE
1	Seal GP Water	5N-6055	Broken	The pump is leak out	C1
2	Body Drive End	3N-8448	Corrosion	The pump is leak out	C2
3	Clip	107-5565	Broken	Bearing is not running well	C3
4	Body Drive End	3N-8447	Corrosion	The pump is leak out	C4
5	Clamp As	3N-8468	Broken	Leak on the connection	C5
6	Pin Cotter	4P-9312	Broken	The nut is not closed maximal	C6
7	Bolt High Temperature	107-4910	Broken, Worn Out	the shaft will vibrate cause not center	C7
8	Ring Retaining	1J-6472	Worn Out	Position of Bearing is not correct	C8
9	Housing Bearing	6I-2092	Worn Out	Position of Bearing is not correct	C9
10	Nut Slotted	7X-2652	Worn Out	The impeller will be vibrate	C10
11	Shaft	7C-3493	Broken, Worn Out	Impeller Pump can not spin	C11
12	Nut Bearing	8B-7614	Worn Out	Position of Bearing is not correct	C12
13	Lock Nut	8B-7613	Worn Out	The nut is not closed maximal	C13
14	Spacer	3N-8445	Worn Out	Position of Bearing is not correct	C14
15	Key	175-6716	Broken, Worn Out	The impeller will be vibrate	C15
16	Bearing Roller	3N-8463	Jammed	The pump can not spin	C16
17	Bearing Inner	4M-6107	Jammed	The pump can not spin	C17
18	Collar Seal	5N-2904	Worn Out	An oil leak occurred	C18
19	Seal Oil	5N-2902	Worn Out	An oil leak occurred	C19
20	Washer	3N-8442	Worn Out	The shaft is not running well	C20
21	Seal O Ring	3N-8462	Break, Worn Out	Leak on the connection	C21
22	Clamp As	3N-8469	Broken	Leak on the connection	C22
23	Ring	3N-8452	Worn Out	The impeller is not running well	C23
24	Impeller	3N-8449	Broken, Corrosion	The pump can not spin, Pressure of water will be reduced	C24
25	Plug	104-1718	Worn Out	A water leak occurred	C25

NO	ITEM	PART NUMBER	POTENTIAL FAILURE	DAMAGE	CODE
26	Plate Port	5N-4504	Worn Out	The pressure of water will be reduced	C26
27	Shim	3N-8441	Worn Out	Position of Impeller is not correct	C27

After the above steps, the values of Severity (S), Occurrence (O), and Detection (D) are determined from each component. Weight of the

causes of failure based on the assessment of four experts. Then calculated to find out the size of the Risk Priority Number.

Table 6. Data Calculation.

CODE	S				O				D				RPN
C1	7	6	8	7	5	5	6	4	4	5	4	4	148,75
C2	2	3	2	2	1	2	2	2	1	1	1	1	3,94
C3	4	4	3	5	4	3	3	3	8	7	7	6	91
C4	2	2	2	3	1	2	2	2	1	1	1	1	3,94
C5	2	2	2	2	2	3	2	3	2	2	1	2	8,75
C6	3	3	3	4	2	3	4	3	8	8	8	8	78
C7	2	2	3	3	1	1	2	1	3	2	2	2	7,03
C8	4	4	5	4	3	4	4	4	8	7	7	7	115,55
C9	5	5	5	5	5	4	5	5	5	5	4	5	112,81
C10	5	5	5	5	2	3	2	3	7	7	6	7	84,38
C11	8	8	8	7	8	8	7	8	7	6	7	8	420,44
C12	5	5	6	6	4	6	5	4	4	4	3	4	97,97
C13	5	5	6	5	3	3	4	3	4	3	3	4	59,72
C14	4	5	5	5	2	3	3	2	7	6	7	6	77,19
C15	7	8	8	8	7	8	8	8	5	5	5	5	300,31
C16	7	8	8	7	7	8	8	7	4	4	5	5	253,13
C17	8	8	8	8	7	7	8	8	4	5	5	5	285
C18	6	6	7	5	5	4	4	3	5	5	5	4	114
C19	7	6	8	7	8	8	8	8	4	4	4	5	238
C20	6	6	5	6	4	4	5	4	5	5	4	5	116,08
C21	5	5	4	6	4	6	5	6	3	3	2	2	65,63
C22	2	2	3	2	2	3	3	3	2	2	2	1	10,83
C23	5	5	6	6	3	3	3	2	8	7	6	6	102,09
C24	7	8	8	8	6	7	6	6	3	3	5	4	181,64
C25	2	2	3	2	2	3	4	3	1	1	1	1	6,75
C26	4	4	3	5	4	4	3	5	7	7	6	5	100
C27	4	3	4	4	3	4	3	3	7	7	8	6	85,31

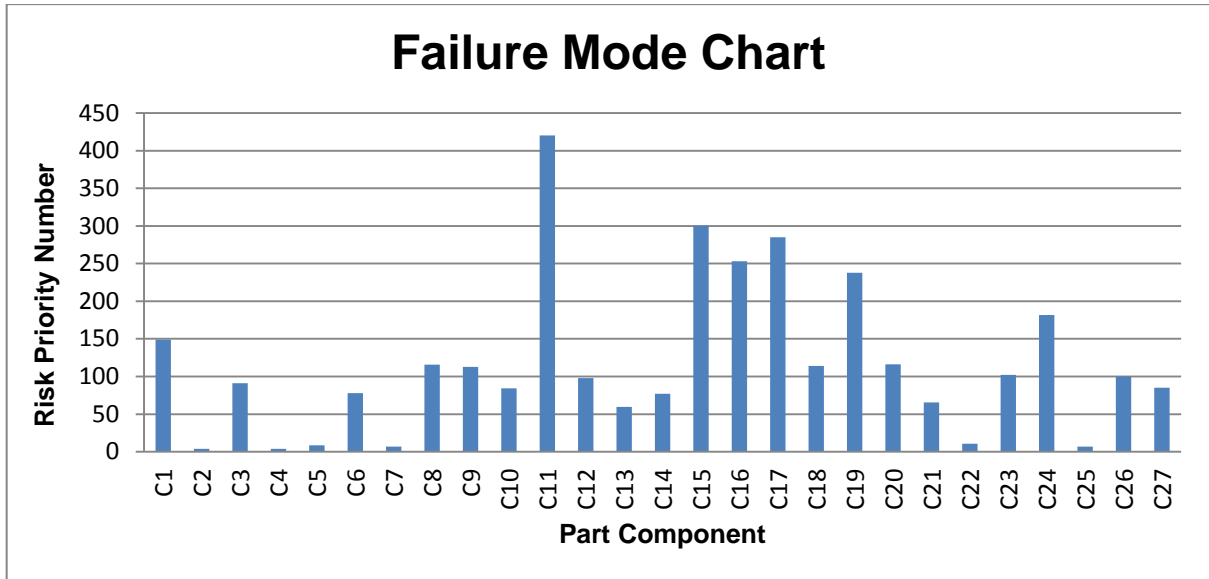

Fig. 4 Failure Mode Chart.

Table 7. Risk Matrix.

No	CODE	Consequence / severity Level	Probability of Failure	Risk Rating
1	C11	3	Probable	High
2	C15	3	Probable	High
3	C17	3	Probable	High
4	C16	3	Probable	High
5	C19	3	Probable	High
6	C24	3	Occasional	High
7	C1	3	Occasional	High
8	C20	3	Remote	Medium
9	C8	2	Remote	Low
10	C18	3	Remote	Medium
11	C9	2	Occasional	Medium
12	C23	2	Remote	Low
13	C26	2	Remote	Low
14	C12	3	Occasional	High
15	C3	2	Remote	Low
16	C27	2	Remote	Low
17	C10	2	Remote	Low
18	C6	2	Remote	Low
19	C14	2	Remote	Low
20	C21	2	Occasional	Medium
21	C13	2	Remote	Low
22	C22	1	Remote	Low
23	C5	1	Remote	Low
24	C7	2	Remote	Low
25	C25	1	Remote	Low
26	C2	1	Remote	Low
27	C4	1	Remote	Low

4. CONCLUSION.

The results of the analysis of 27 components on the Caterpillar 3412 Sea Water Pump Diesel Generator, obtained 7 components that have RPN values above the average and have Risk Rating High categorize. The following are the 4 components with the highest RPN value, namely Shaft (7C-3493) RPN value 420.44; Key (175-6716) RPN value of 300.31; Bearing Inner (4M-6107) RPN 285 value and Bearing Roller (3N-8463) RPN value 253.13. Components that have high RPN values require more attention, such as routine checks and periodic maintenance, so that the lifetime of the machine will increase and always be ready to operate.

REFERENCES

- ABS. (2016). *Surveys Based on Machinery Reliability and Maintenance Techniques*. New York: American Bureau of Shipping.
- ARMY, D. o. (2006). *Failure Modes, Effect and Criticality Analysis (FMECA) for Command, Control, Communication, Computer, Intelligence, Surveillance, and Reconnaissance (C4ISR) Facilities*. Washington D.C.
- Borgovini, R., Pemberton, S., & Rossi, M. (1993). *Failure Mode, Effects and Criticality Analysis (FMECA)*. New York: Reliability Analysis Center.
- Caterpillar. (2004). *Parts manual 3412 C Marine Auxiliary Generator Set*.
- Choudhary, S., Tiwari, A., Vardhan, A., & Kaushal, A. (2014). The Effect of Engine Temperature on Multi Cylinder SI Engine Performance with Gasoline as a fuel. *International Journal of Engineering Research and General Science*, 2(5), 497-505.
- Deng, Y. (2015). A Research on Subway Physical Vulnerability Based on Network Theory and FMECA. *Journal of Safety Science*, 127-134.
- Hasbullah, N. H., & Ahmad, R. (2015). Failure Analysis of Tyre Production Process Using FMECA Method. *Case Studies in Engineering Failure Analysis*.
- Jun, L., & Huibin, X. (2012). Reliability Analysis of Aircraft Equipment Based on FMECA Method. *Physics Procedia*, 25, 1816 – 1822.
- Karassik, I. J., Messina, J. P., Cooper, P., & Heald, C. C. (2001). *Pump Handbook* (3rd ed.). New York: McGraw-Hill.
- Melani, A. H., Murad, C. A., Netto, A. C., Souza, G. F., & Nabeta, S. I. (2018). Criticality-based Maintenance of a Coal-fired Power Plant. *Energy*, 147, 767-781.
- Parrondo, J. L., Velarde, S., & Santolaria, C. (1998). Development of a Predictive Maintenance System For a Centrifugal Pump. *Journal of Quality in Maintenance Engineering*, 3, 198-211.
- Parrondo, J., Fernandez, J., Santolaria, C., & Gonzalez, J. (1996). Measurements in The Dynamic Pressure Field of The Volute of a Centrifugal Pump. *Hydraulic Machinery and Cavitation*, 401-410.
- V.R. Renjith, M. J. (2018, January). Fuzzy FMECA (failure mode effect and criticality analysis) of LNG Storage Facility. *Journal of Loss Prevention in the Process Industries*.